

PROPOSED INTERFACE REVISION NOTICE (PIRN)

Note: This Cover Page is not intended for signature. It is to be used during the document update (pre-ICWG) process.

Affected ICD/IS:
IS-GPS-800 Rev D

PIRN Number:
PIRN-IS-800D-003

Authority:
RFC-00312

PIRN Date: 22-JUN-2016

CLASSIFIED BY: N/A

DECLASSIFY ON: N/A

Document Title: Navstar GPS Space Segment/ User Segment L1C Interfaces

Reason For Change (Driver): To remove ambiguity in contractor interpretation, the definition of the parameter Time of Predict (T_{op}) and other timing parameters must be clarified in the GPS technical baseline documentation.

Description of Change: Process the proposed changes with the correct stakeholders and update IS-GPS-800 Rev D for accurate implementation.

Prepared By: John Buckley

Checked By: Perry Chang

DISTRIBUTION STATEMENT A: Approved For Public Release; Distribution Is Unlimited

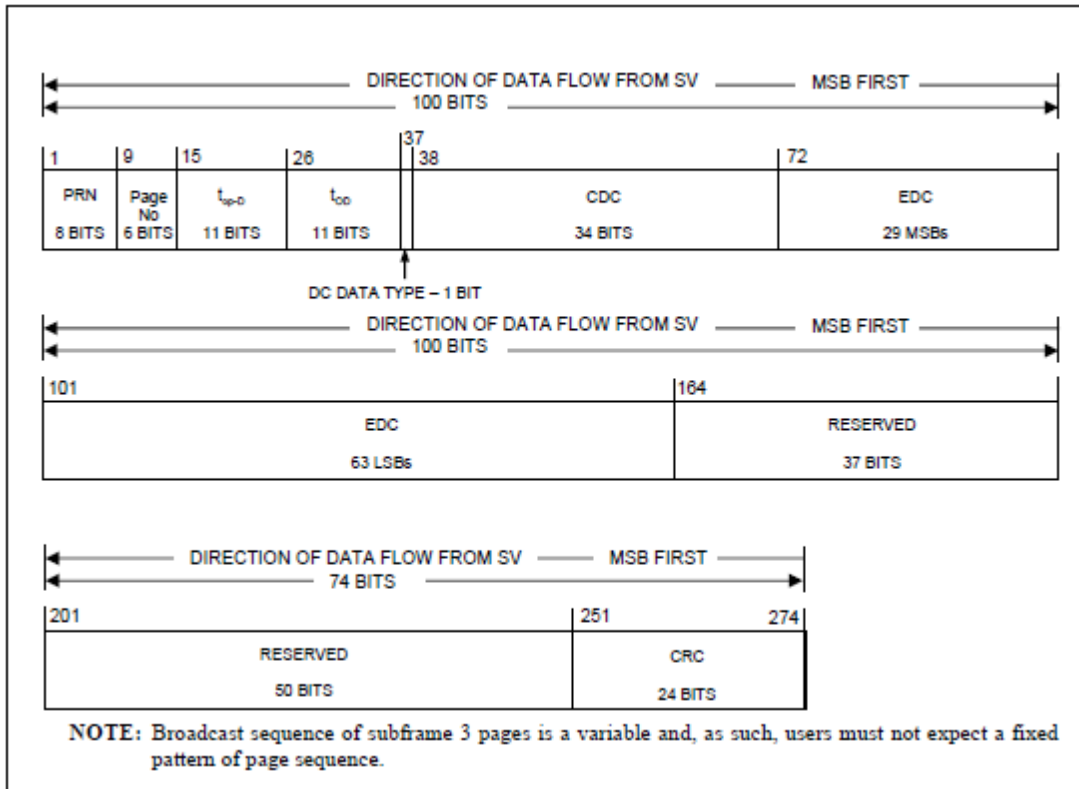

WAS :

Figure 3.5-6. Subframe 3, Page 5 - Differential Correction

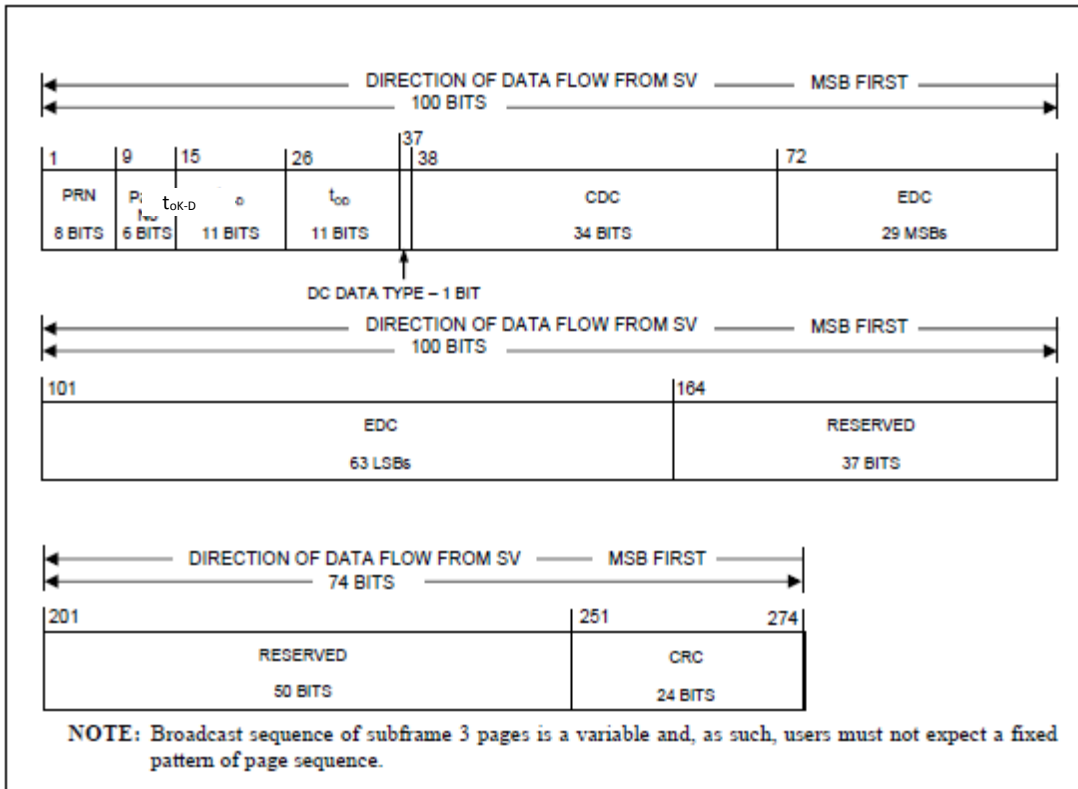

IS :

Figure 3.5-6. Subframe 3, Page 5 - Differential Correction

Req ID : IS800-157

WAS : Any change in the subframe 2 ephemeris and clock data shall be accomplished with a simultaneous change in the t_{oe} value. The SV shall assure that the t_{oe} value, for at least the first data set transmitted by an SV after an upload, is different from that transmitted prior to the cutover. The eight LSBs of t_{oe} for each data set shall be different from the eight LSBs of t_{oe} transmitted during the previous six hours by the SV.

IS : Any change in the subframe 2 ephemeris and clock data shall be accomplished with a simultaneous change in the t_{oe} value. The SV shall assure that the t_{oe} value, for at least the first data set transmitted by an SV from a new ICE data projection sequence, is different from that transmitted from the prior ICE data projection sequence. The eight LSBs of t_{oe} for each data set shall be different from the eight LSBs of t_{oe} transmitted during the previous six hours by the SV.

Req ID : IS800-159

WAS :

Table 3.5-1. Subframe 2 Parameters (1 of 3)

Parameter		No. of Bits**	Scale Factor (LSB)	Effective Range***	Units
WN	Week No.	13	1		weeks
ITOW	Interval time of week	8		83	(see text)
t_{op}	Data predict time of week	11	300	604,500	seconds
L1C health		1			(see text)
URA _{ED} Index	ED accuracy index	5*			(see text)
t_{oe}	Ephemeris/clock data reference time of week	11	300	604,500	seconds
ΔA ****	Semi-major axis difference at reference time	26*	2^{-9}		meters
\dot{A}	Change rate in semi-major axis	25*	2^{-21}		meters/sec
Δn_0	Mean Motion difference from computed value at reference time	17*	2^{-44}		semi-circles/sec
$\dot{\Delta n}_0$	Rate of mean motion difference from computed value	23*	2^{-57}		semi-circles/sec ²
M_{0-n}	Mean anomaly at reference time	33*	2^{-32}		semi-circles
e_n	Eccentricity	33	2^{-34}		dimensionless
ω_n	Argument of perigee	33*	2^{-32}		semi-circles
<p>* Parameters so indicated are in two's complement notation; ** See Figure 3.5-1 for complete bit allocation in Subframe 2; *** Unless otherwise indicated in this column, effective range is the maximum range attainable with indicated bit allocation and scale factor. **** Relative to $A_{REF} = 26,559,710$ meters.</p>					

IS :

Table 3.5-1. Subframe 2 Parameters (1 of 3)				
Parameter	No. of Bits**	Scale Factor (LSB)	Effective Range***	Units

WN	Week No.	13	1		weeks
ITOW	Interval time of week	8		83	(see text)
t_{top}	ICE Data projection sequence time of week	11	300	604,500	seconds
L1C health		1			(see text)
URA _{ED} Index	ED accuracy index	5*			(see text)
t_{oe}	Ephemeris/clock data reference time of week	11	300	604,500	seconds
ΔA ****	Semi-major axis difference at reference time	26*	2^{-9}		meters
\dot{A}	Change rate in semi-major axis	25*	2^{-21}		meters/sec
Δn_0	Mean Motion difference from computed value at reference time	17*	2^{-44}		semi-circles/sec
$\dot{\Delta n}_0$	Rate of mean motion difference from computed value	23*	2^{-57}		semi-circles/sec ²
M_{0-n}	Mean anomaly at reference time	33*	2^{-32}		semi-circles
e_n	Eccentricity	33	2^{-34}		dimensionless
ω_n	Argument of perigee	33*	2^{-32}		semi-circles
<p>* Parameters so indicated are in two's complement notation; ** See Figure 3.5-1 for complete bit allocation in Subframe 2; *** Unless otherwise indicated in this column, effective range is the maximum range attainable with indicated bit allocation and scale factor. **** Relative to $A_{REF} = 26,559,710$ meters.</p>					

Req ID : IS800-161

WAS :

Table 3.5-1. Subframe 2 Parameters (3 of 3)					
Parameter		No. of Bits**	Scale Factor (LSB)	Effective Range***	Units
URA _{NED0} Index	NED Accuracy Index	5*			(see text)
URA _{NED1} Index	NED Accuracy Change Index	3			(see text)

URANED2 Index	NED Accuracy Change Rate Index	3			(see text)
af2-n	SV Clock Drift Rate Correction Coefficient	10*	2 ⁻⁶⁰		sec/sec ²
af1-n	SV Clock Drift Correction Coefficient	20*	2 ⁻⁴⁸		sec/sec
af0-n	SV Clock Bias Correction Coefficient	26*	2 ⁻³⁵		seconds
TGD****	Inter-Signal Correction for L1 or L2 P(Y)	13*	2 ⁻³⁵		seconds
ISCLICP****	Inter-Signal Correction for L1CP	13*	2 ⁻³⁵		seconds
ISCLICD****	Inter-Signal Correction for L1CD	13*	2 ⁻³⁵		seconds
WNOP	Data Predict Week Number	8	1		weeks

* Parameters so indicated are in two's complement notation;
** See Figure 3.5-1 for complete bit allocation in Subframe 2;
*** Unless otherwise indicated in this column, effective range is the maximum range attainable with indicated bit allocation and scale factor.
**** The bit string of "100000000000" will indicate that the group delay value is not available.

IS :

Table 3.5-1. Subframe 2 Parameters (3 of 3)					
Parameter		No. of Bits**	Scale Factor (LSB)	Effective Range***	Units
URANED0 Index	NED Accuracy Index	5*			(see text)
URANED1 Index	NED Accuracy Change Index	3			(see text)
URANED2 Index	NED Accuracy Change Rate Index	3			(see text)
af2-n	SV Clock Drift Rate Correction Coefficient	10*	2 ⁻⁶⁰		sec/sec ²

a_{f1-n}	SV Clock Drift Correction Coefficient	20*	2^{-48}		sec/sec
a_{f0-n}	SV Clock Bias Correction Coefficient	26*	2^{-35}		seconds
T_{GD}^{****}	Inter-Signal Correction for L1 or L2 P(Y)	13*	2^{-35}		seconds
ISC_{L1CP}^{****}	Inter-Signal Correction for L1C _P	13*	2^{-35}		seconds
ISC_{L1CD}^{****}	Inter-Signal Correction for L1C _D	13*	2^{-35}		seconds
WN_{OP}	ICE Data Projection Sequence Week Number	8	1		weeks
<p>* Parameters so indicated are in two's complement notation;</p> <p>** See Figure 3.5-1 for complete bit allocation in Subframe 2;</p> <p>*** Unless otherwise indicated in this column, effective range is the maximum range attainable with indicated bit allocation and scale factor.</p> <p>**** The bit string of "100000000000" will indicate that the group delay value is not available.</p>					

Req ID : IS800-166

WAS : Data Predict Time of Week

IS : ICE Data Projection Sequence Time of Week.

Req ID : IS800-167

WAS : Bits 22 through 32 of subframe 2 shall contain the data predict time of week (t_{op}). The t_{op} term provides the epoch time of week of the state estimate utilized for the prediction of satellite quasi-Keplerian ephemeris parameters.

IS : Bits 22 through 32 of subframe 2 shall contain the data predict time of week (t_{op}). The t_{op} term provides the epoch time of week of the state data utilized for the projection of satellite ICE data quasi-Keplerian ephemeris parameters. Users are cautioned to avoid using this parameter to compute age of data for any SV.

Req ID : IS800-179

WAS : The user shall compute the ECEF coordinates of position for the SV's antenna phase center (APC) utilizing a variation of the equations shown in Table 3.5-2. The ephemeris parameters are Keplerian in appearance; however, the values of these parameters are produced by the SV via a least squares curve fit of the predicted ephemeris of the SV APC (time-position quadruples: t, x, y, z expressed in ECEF coordinates). Particulars concerning the applicable coordinate system are given in Sections 20.3.3.4.3.3 and 20.3.3.4.3.4 of IS-GPS-200.

IS : The user shall compute the ECEF coordinates of position for the SV's antenna phase center (APC) utilizing a variation of the equations shown in Table 3.5-2. The ephemeris parameters are Keplerian in appearance; however, the values of these parameters are produced by the SV via a least squares curve fit of the projected ephemeris of the SV APC (time-position quadruples: t, x, y, z expressed in ECEF coordinates). Particulars concerning the applicable coordinate system are given in Sections 20.3.3.4.3.3 and 20.3.3.4.3.4 of IS-GPS-200.

Req ID : IS800-904

WAS : **Data Predict Week Number.**

IS : **ICE Data Projection Sequence Week Number.**

Req ID : IS800-905

WAS : Bits 567-574 of Subframe 2 shall indicate the Data Predict Week Number (WN_{OP}) to which the Data Predict Time of Week (top) is referenced (see 3.5.3.3). The WN_{OP} term consists of eight bits which shall be a modulo 256 binary representation of the GPS week number to which the top is referenced.

IS : Bits 567-574 of Subframe 2 shall indicate the ICE Data Projection Sequence Week Number. (WN_{OP}) to which the ICE Data Projection Sequence Time of Week. (top) is referenced (see 3.5.3.3). The WN_{OP} term consists of eight bits which shall be a modulo 256 binary representation of the GPS week number to which the top is referenced.

Req ID : IS800-269

WAS : **Differential Correction Data Predict Time of Week**

IS : **Differential Correction Data Kalman Time of Week**

Req ID : IS800-270

WAS : The DC data predict time of week (t_{op-D}) provides the epoch time of week, in increments of 300 seconds (i.e. five minutes), at which the prediction for the associated DC data was performed.

IS : The DC data Kalman time of week (t_{oK-D}) provides the epoch time of week, in increments of 300 seconds (i.e. five minutes), at which the kalman estimation for the associated DC data was performed.

Req ID : IS800-289

WAS : Cutovers of subframe 2 data to new data sets will nominally occur on hour boundaries except for the first data set of a new upload. The first data set of newly uploaded data will cutover on 15 minute boundaries.

IS : Cutovers of subframe 2 data to new data sets will nominally occur on hour boundaries except for the first data set of a new ICE data projection sequence. The first data set of newly uploaded data will cutover on 15 minute boundaries.

Req ID : IS800-871

WAS : The t_{oe} shall be equal to the t_{oc} of the same CNAV data set. The following rules govern the transmission of t_{oe} and t_{oc} values in different data sets: (1) The transmitted t_{oc} will be different from any value transmitted by the SV during the preceding seven days; (2) The transmitted t_{oe} will be different from any value transmitted by the SV during the preceding six hours.

Cutovers to new data sets will occur only on hour boundaries except for the first data set of a new upload. The first data set may be cut-in (reference paragraph 3.5.5.1) at any time during the hour and therefore may be transmitted by the SV for less than one hour.

The start of the transmission interval for each data set corresponds to the beginning of the curve fit interval for the data set. Each data set remains valid for the duration of its transmission interval, and nominally also remains valid for the duration of its curve fit interval. A data set is rendered invalid before the end of its curve fit interval when it is superseded by the SV cutting over to the first data set of a new upload.

Normal Operations. The subframe 2 data sets are transmitted by the SV for periods of two hours. The corresponding curve fit interval is three hours.

IS : The t_{oe} shall be equal to the t_{oc} of the same CNAV data set. The following rules govern the transmission of t_{oe} and t_{oc} values in different data sets: (1) The transmitted t_{oc} will be different from any value transmitted by the SV during the preceding seven days; (2) The transmitted t_{oe} will be different from any value transmitted by the SV during the preceding six hours.

Cutovers to new data sets will occur only on hour boundaries except for the first data set of a new ICE data projection sequence. The first data set may be cut-in (reference paragraph 3.5.5.1) at any time during the hour and therefore may be transmitted by the SV for less than one hour.

The start of the transmission interval for each data set corresponds to the beginning of the curve fit interval for the data set. Each data set remains valid for the duration of its transmission interval, and nominally also remains valid for the duration of its curve fit interval. A data set is rendered invalid before the end of its curve fit interval when it is superseded by the SV cutting over to the first data set of a new ICE data projection sequence.

WAS :

APC	-	antenna phase center
ASCII	-	American Standard Code for Information Interchange
BCH	-	Bose, Chaudhuri, and Hocquenghem
BOC	-	Binary Offset Carrier
BPSK	-	Bi-Phase Shift Key
CCB	-	Configuration Control Board
CDC	-	clock differential correction
CNAV-2-	-	L1C Navigation Message
CRC	-	Cyclic Redundancy Check
CS	-	Control Segment
dBc	-	Power ratio of a signal to a (unmodulated) carrier signal, expressed in decibels
DC	-	differential correction
DN	-	Day Number
ECEF	-	Earth-Centered, Earth-Fixed
ECI	-	Earth-Centered, Inertial
EDC	-	ephemeris differential correction
EOE	-	Edge-of-Earth
EOL	-	End-of-Life
EOP	-	Earth Orientation Parameters
FEC	-	Forward Error Correction
GBAS	-	Ground Based Augmentation System
GGTO	-	GPS/GNSS Time Offset
GNSS	-	Global Navigation Satellite System
GPS	-	Global Positioning System
GPSW	-	GPS Wing
ICC	-	Interface Control Contractor

ICWG	-	Interface Control Working Group
IRN	-	Interface Revision Notice
IS	-	Interface Specification
ISC	-	Inter-Signal Correction
ITOW	-	Interval Time of Week
LDPC	-	Low Density Parity Check
LFSR	-	Linear Feedback Shift Register
LSB	-	Least Significant Bit
LSF	-	Leap Seconds Future
L1C	-	Common L1 Signal
MCS	-	Master Control Station
MHz	-	Megahertz
MSB	-	Most Significant Bit
NAV	-	Legacy Navigation Message, D(t)
NSCD	-	non-standard L1C _D
NSCP	-	non-standard L1C _P
PIRN	-	Proposed Interface Revision Notice
PRN	-	Pseudo-Random Noise
RF	-	Radio Frequency
RHCP	-	Right-Hand Circularly Polarized
RMS	-	Root Mean Square
SBAS	-	Satellite Based Augmentation System
sps	-	symbols per second
SS	-	Space Segment
SSV	-	Space Service Volume
SV	-	Space Vehicle
TBD	-	To Be Determined
TBR	-	To Be Resolved
TBS	-	To Be Supplied
TMBOC	-	Time-Multiplexed BOC

TOI	-	Time of Interval
TOW	-	Time of Week
UDRA	-	User Differential Range Accuracy
UE	-	User Equipment
URA	-	User Range Accuracy
US	-	User Segment
USNO	-	U.S. Naval Observatory
UTC	-	Coordinated Universal Time
WGS 84	-	World Geodetic System 1984

IS :

APC	-	antenna phase center
ASCII	-	American Standard Code for Information Interchange
BCH	-	Bose, Chaudhuri, and Hocquenghem
BOC	-	Binary Offset Carrier
BPSK	-	Bi-Phase Shift Key
CCB	-	Configuration Control Board
CDC	-	clock differential correction
CNAV-2-	-	L1C Navigation Message
CRC	-	Cyclic Redundancy Check
CS	-	Control Segment
dBc	-	Power ratio of a signal to a (unmodulated) carrier signal, expressed in decibels
DC	-	differential correction
DN	-	Day Number
ECEF	-	Earth-Centered, Earth-Fixed
ECI	-	Earth-Centered, Inertial
EDC	-	ephemeris differential correction

EOE	-	Edge-of-Earth
EOL	-	End-of-Life
EOP	-	Earth Orientation Parameters
FEC	-	Forward Error Correction
GBAS	-	Ground Based Augmentation System
GGTO	-	GPS/GNSS Time Offset
GNSS	-	Global Navigation Satellite System
GPS	-	Global Positioning System
GPSW	-	GPS Wing
ICC	-	Interface Control Contractor
ICE		Integrity/Clock/Ephemeris
ICWG	-	Interface Control Working Group
IRN	-	Interface Revision Notice
IS	-	Interface Specification
ISC	-	Inter-Signal Correction
ITOW	-	Interval Time of Week
LDPC	-	Low Density Parity Check
LFSR	-	Linear Feedback Shift Register
LSB	-	Least Significant Bit
LSF	-	Leap Seconds Future
L1C	-	Common L1 Signal
MCS	-	Master Control Station
MHz	-	Megahertz
MSB	-	Most Significant Bit
NAV	-	Legacy Navigation Message, D(t)
NSCD	-	non-standard L1C _D
NSCP	-	non-standard L1C _P
PIRN	-	Proposed Interface Revision Notice
PRN	-	Pseudo-Random Noise
RF	-	Radio Frequency

RHCP	-	Right-Hand Circularly Polarized
RMS	-	Root Mean Square
SBAS	-	Satellite Based Augmentation System
sps	-	symbols per second
SS	-	Space Segment
SSV	-	Space Service Volume
SV	-	Space Vehicle
TBD	-	To Be Determined
TBR	-	To Be Resolved
TBS	-	To Be Supplied
TMBOC	-	Time-Multiplexed BOC
TOI	-	Time of Interval
TOW	-	Time of Week
UDRA	-	User Differential Range Accuracy
UE	-	User Equipment
URA	-	User Range Accuracy
US	-	User Segment
USNO	-	U.S. Naval Observatory
UTC	-	Coordinated Universal Time
WGS 84	-	World Geodetic System 1984

Req ID : IS800-911

WAS : N/A

IS : Integrity/Clock/Ephemeris (ICE) Data Set.

Req ID : IS800-912

WAS : N/A

IS : An Integrity/Clock/Ephemeris (ICE) data set is the collection of SV-specific URA parameters, clock correction polynomial parameters, ephemeris parameters, and related parameters (health flags, time tags, etc.) needed to use the SV's broadcast signal(s) in the positioning service. ICE data is sometimes also known as the user's 'hot start' data for the SV. Before modernization, an ICE data set was sometimes called a "Subframe 1-2-3 data set".

Req ID : IS800-913

WAS : N/A

***IS* : ICE Data Projection Sequence.**

Req ID : IS800-914

WAS : N/A

IS : A related time-ordered sequence of ICE data sets in which each successive ICE data set is a time projection of the preceding ICE data set. Special provisions apply to alert users to discontinuities separating one ICE data projection sequence from another ICE data projection sequence (e.g., after an upload occurs). Before modernization, an ICE data projection sequence was sometimes called an "uploaded sequence of Subframe 1-2-3 data sets". Beginning with the Next Generation Operational Control System (OCX), an upload may include multiple, disjoint but contiguous ICE data projection sequences.